

Agreement No. ZECO/GR/02/2021/02

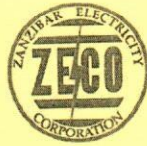

**CONTRACT AGREEMENT**

**BETWEEN**

**ZANZIBAR ELECTRICITY COOPERATION**

**AND**

**FASIMA GENERAL TRADERS**

**FOR THE SUPPLY OF HIGH TENSION & LOW TENSION UNDER COVID 19  
PROJECT**

**WHERE AS:**

**THIS CONTRACT AGREEMENT** is made this <sup>08<sup>th</sup></sup>..... day of  
..... <sup>FEBRUARY</sup>..... 2022

**BETWEEN**

Zanzibar Electricity Corporation of P.O. Box 235, Gulioni,  
Zanzibar (hereinafter referred to as "the Client" which expression  
includes its successor and assignee) of the one part,

**AND**

Fasima General Traders of P.O. BOX 3654, Muembe ladu, Zanzibar  
(hereinafter referred to as "the Supplier" which expression includes  
its successor and assignee) of the other part:

**WHERE AS:**

- a. The Purchaser is an autonomous body established under the laws of Zanzibar for the Supply of Electricity,
- b. The Supplier is an undertaking registered under the laws of Zanzibar and which authorized to trade in the business of

supplying **High Tension & Low Tension Materials** within Zanzibar,

- c. The Purchaser is in demand of the **High Tension & Low Tension Materials** in the sum of **TZS One Billion, Six Hundred Fifty Million, Nine Hundred Thousand Nighty Five Thousand, Eighty Hundred Eight Only (VAT INCLUSIVE)** in words (**TZS 1,650,995,880.00**) and
- d. The Supplier has won the lot 2B floated by the Purchaser inviting tenders for the supply of **High Tension & Low Tension Materials**.

**THEREFORE, ON THE BASIS OF PRINCIPLES OF EQUALITY AND MUTUAL INTERESTS, THE PARTIES DO HEREBY AGREE AS:**

1. The following documents are forming part to the contract and shall be considered as mutually explanatory of one another: -
  - a. This Form of Contract
  - b. Price Schedule submitted by the Tenderer;
  - c. The Schedule of Requirements;
  - d. The Technical Specifications;
  - e. The manufacturer authorization;
  - f. The anti-bribery/ code of conduct,
  - g. The Special Conditions of Contract;
  - h. The General Conditions of Contract and;
  - i. Power of attorney;
2. This contract shall prevail over the other documents part of the contract and in the event of any discrepancy or inconsistency within the contract documents, the documents shall prevail in the descending order as arranged in the clause 1 of this contract.

3. In consideration of the payments to be made by the Purchaser to the **Supplier** as hereinafter stated, the **Supplier** shall supply the **High Tension and Low Tension Materials** to the Purchaser in conformity, in all respect, with the provision of the Contract and remedy defects therein.
4. Subject to clause 3 of this contract, the **Purchaser** hereby covenants to pay the **Supplier** in consideration of the supply, the contract price or such other sum as may become payable under the provisions of the Contract at the times and in the manner prescribed in the Contract.
5. This contract may not be amended, or otherwise extended, except by written contract between the parties and no other purported amendment or extension thereof shall be effective.

**IN WITNESS WHEREOF**, the parties hereto have, through their duly authorized agents, set their hands the day, month and the year as herein indicated.

Signed for and on behalf of the **Supplier**:

Name..... RAJAB MOH'D MGENI .....

In the presence of:

Designation MANAGING DIRECTOR (MD) Name ... J. E. L. N. ALI HASSAN .....

Signature..... [Signature] .....

Signature..... [Signature] .....



[Handwritten mark]

Signed for and on behalf of the **Purchaser:**

Name THABTI-S-KHAMUS.....

In the presence of:

Designation Ag. GENERAL MANAGER.....

Name ARAFAT S. KHAMUS.....

Signature .....

Signature .....

ZANZIBAR ELECTRICITY CORPORATION P. O. Box 235 SIGN..... DATE.....
---



## General Conditions of Contract

<b>1.</b>	<b>Definit ions</b>	1.1	In this Contract, the following terms shall be interpreted as indicated:
			a) "The Contract" means the agreement entered into between the Purchaser and the Supplier, as recorded in the Contract Form signed by the parties, including all attachments and appendices thereto and all documents incorporated by reference therein.
			b) "Completion" means the fulfillment of the related services by the Supplier in accordance with the terms and conditions set forth in the contract
			c) "The Contract Price" means the price payable to the Supplier as specified under the Contract, subject to such additions and adjustment here to or deduction there from as may be made pursuant to the contract for the full and proper performance of its contractual obligations.
			d) "Delivery" means the transfer of the goods from the supplier equipment, machinery, and /or other materials, which the Supplier is required to supply to the Purchaser under Contract.
			f) "The Related Services" means those services ancillary to the supply of the Goods, such as transportation and insurance, and any other incidental services, such as installation, commissioning, provision of technical assistance, training, initial

				maintenance and other such obligations of the Supplier covered under the Contract.
			g)	“GCC” means the General Conditions of Contract contained in this section.
			h)	“SCC” means the Special Conditions of Contract.
			i)	“The Purchaser” means the entity purchasing the Goods and related service, as named in <b>SCC</b> .
			j)	“The Supplier” means the individual private or government entity or a combination of the above who’s Tender to perform the contract has been accepted by the Purchaser and is named as such in the Contract Agreement, and includes the legal successors or permitted assigns of the supplier.
			k)	“The Project Site” where applicable, means the place or places named in SCC.
			l)	“Day” means calendar day.
			m)	'Effective Date" means the date on which this Contract becomes effective pursuant to GCC Clause
			n)	'Eligible Country" means the countries and territories eligible for participation in procurements financed by the specified institution.
			o)	“End User" means the organization(s) where the goods will be used, as <b>named in the SCC</b> .
			p)	“Origin” means the place where the Goods were mined, grown, or produced or from

			which the Services are supplied. Goods are produced when, through manufacturing, processing, or substantial and major assembly of components, a commercially recognized new produce results that is substantially different in basic characteristics or in purpose or utility from its components.
			q) "Force Majeure" means an event or situation beyond the control of the Supplier and not involving the Supplier's fault or negligence and not foreseeable, is unavoidable, and is not due to negligence or lack of care on the part of the Supplier.
2.	<b>Applic ation</b>	2.1	These General Conditions shall apply to the extent that provisions of other parts of the Contract do not supersede them.
3.	<b>Govern ing Langua ge</b>	3.1	The Contract as all correspondence and documents relating to the contract exchanged by the Supplier and the Purchaser shall be written in the language <b>specified in SCC</b> . Subject to GCC Clause 3.1, the version of the Contract written in the specified language shall govern its interpretation.
4.	<b>Applic able Law</b>	4.1	The contract shall be governed and interpreted in accordance with the laws of Zanzibar, unless otherwise <b>specified in SCC</b> .
5.	<b>Countr y of Origin</b>	5.1	The origin of Goods and Services is distinct from the nationality of the Supplier.

6.	<b>Standards</b>	6.1	The Goods supplied under this Contract shall conform to the standards mentioned in the Technical Specifications, and, when no applicable standard is mentioned, to the authoritative standards appropriate to the Goods' country of origin. Such standards shall be the latest issued by the concerned institution.
7.	<b>Use of Contract Documents and Information; Inspection and Audit by the Government of Zanzibar</b>	7.1	The Supplier shall not, without the Purchaser's prior written consent, disclose the Contract, or any provision thereof, or any specification, plan, drawing, pattern, sample, or information furnished by or on behalf of the Purchaser in connection therewith, to any person other than a person employed by the Supplier in the performance of the Contract. Disclosure to any such employed person shall be made in confidence and shall extend only so far as may be necessary for purposes of such performance.
		7.2	The Supplier shall not, without the Purchaser's prior written consent, make use of any document or information enumerated in GCC Clause 7.1 except for purposes of performing the Contract.
		7.3	Any document, other than the Contract itself, enumerated in GCC Clause 7.1 shall remain the property of the Purchaser and shall be returned (all copies) to the Purchaser on completion of the Supplier's performance under the Contract if so required by the Purchaser.



		7.4	The Supplier shall permit the Revolutionary Government of Zanzibar or / and donor agencies involved in financing the project to inspect the Supplier's accounts and records relating to the performance of the Supplier and to have them audited by auditors appointed by the Revolutionary Government of Zanzibar or / and the appropriate donor agencies, if so required by the Revolutionary Government of Zanzibar or / and the appropriate donor agencies.
8.	<b>Patent and Copyrights</b>	8.1	The Supplier shall indemnify the Purchaser against all third-party claims of infringement of patent, trademark, or industrial design rights arising from use of the Goods or any part thereof in Zanzibar.
		8.2	The patent right in all drawings, documents, and other materials containing data and information furnished to the Purchaser by the Supplier herein shall remain vested in the supplier, or, if they are furnished to the Purchaser directly, or through the Supplier by any third party, including suppliers of materials, the patent right in such materials shall remain vested in such third party.
9.	<b>Performance Security</b>	9.1	Within thirty (30) days of receipt of the notification of Contract award, the successful Tenderer shall furnish to the Purchaser the performance security in the amount <b>specified in SCC.</b>
		9.2	The proceeds of the performance security shall be payable to the Purchaser as compensation for any loss resulting from the Supplier's failure to complete its obligations under the Contract.

		9.3	The performance security shall be denominated in the currency of the Contract, or in a freely convertible currency acceptable to the Purchaser and shall be in one of the following forms:
		a)	A bank guarantee, an irrevocable letter of credit issued by a reputable bank, or an insurance bond issued by a reputable insurance firm located in Zanzibar/Tanzania or abroad, acceptable to the Purchaser, in the form provided in the Tendering documents or another form acceptable to the Purchaser; or
		b)	A cashier's or certified check.
		9.4	The performance security will be discharged by the Purchaser and returned to the Supplier not later than thirty (30) days following the date of completion of the Supplier's performance obligations under the Contract, including any warranty obligations, unless otherwise <b>specified in SCC</b> .
<b>1 0</b>	<b>Inspections and Test</b>	10.1	The Purchaser or its representative shall have the right to inspect and /or to test the Goods to confirm their conformity to the Contract specifications at no extra cost to the Purchaser. <b>SCC</b> and the Technical Specifications shall specify what inspections and tests the Purchaser shall notify the Supplier in writing, in a timely manner, of the identity of any representatives retained for these purposes.

		10.2	The inspections and tests may be conducted on the premises of the Supplier or its subcontractor(s), at point of delivery, and/or at the Goods' final destination. If conducted on the premises of the Supplier or its subcontractor(s), all reasonable facilities and assistance, including access to drawings and production data, shall be furnished to the inspectors at no charge to the Purchaser.
		10.3	Should any inspected or tested Goods fail to conform to the Specifications, the Purchaser may reject the Goods, and the Supplier shall replace the rejected Goods to meet specification requirements free of cost to the Purchaser.
		10.4	The Purchaser's right to inspect, test and, where necessary, reject Goods after the Goods' arrival in the Purchaser's country shall in no way be limited or eared by reason of the Goods having previously been inspected, tested, and passed by the Purchaser or its representative prior to the Goods' shipment from the country of origin.
		10.5	Nothing in GCC Clause 10 shall in any way release the supplier from any warranty or other obligations under this Contract.

1 1	Packin g	11.1	The supplier shall provide such packing of the Goods as is required to prevent their damage or deterioration during transit to their final destination, as indicated in the Contract. The packing shall be sufficient to withstand, without limitation, rough handling during transit and exposure to extreme temperatures, salt and precipitation during transit, and open storage. Packing case size and weights shall take into consideration, where appropriate, the remoteness of the Goods final destination and the absence of heavy handling facilities at all points in transit.
		11.2	The packing, marking, and documentation within and outside the packages shall comply strictly with such special requirements as shall be expressly provided for in the Contract, including additional requirements, if any, <b>specified in SCC</b> , and in any subsequent instructions ordered by the Purchaser.
1 2	<b>Deliver y and Docum ents</b>	12.1	The Supplier in accordance with the terms specified in the Schedule of Requirements shall make delivery of the Goods. The details of shipping and / or other documents to be furnished by the Supplier are <b>specified in SCC</b> .
		12.2	For purposes of the Contract, “EXW” “FOB” “FCA”, “CIF”, “CIP,” and other trade terms used to describe the obligations of the parties shall have the meanings assigned to them by the current edition of INCOTERMS published by the International Chamber of Commerce, Paris.
		12.3	Documents to be submitted by the Supplier are <b>specified in SCC</b> .

1 3	<b>Insurance</b>	13.1	The Goods supplied under the Contract shall be fully insured in a freely convertible currency against loss or damage incidental to manufacture or acquisition, transportation, storage, and delivery in the manner <b>specified in the SCC.</b>
1 4	<b>Transportation</b>	14.1	Where the Supplier is required under Contract to deliver the Goods FOB, transport of the Goods, up to and including the point of putting the Goods on board the vessel at the specified port of loading, shall be arranged and paid for by the Supplier, and the cost thereof shall be included in the Contract Price. Where the Supplier is required under the Contract to deliver the Goods FCA, transport of the Goods and delivery into the custody of the carrier at the place named by the Purchaser or other agreed point shall be arranged and paid for by the Supplier, and the cost thereof shall be included in the Contract Price.
		14.2	Where the Supplier is required under Contract to deliver the Goods CIF or CIP, transport of the Goods to the port of destination or such other named place of destination in Dar-es- Salaam, as shall be specified in the Contract, shall be arranged and paid for by the Supplier, and the cost thereof shall be included in the Contract Price.

		14.3	Where the Supplier is required under the Contract to transport the Goods to a specified place of destination within Zanzibar, defined as the Project Site, transport to such place of destination in Zanzibar, including insurance and storage, as shall be specified in the Contract, shall be arranged by the Supplier, and related costs shall be included in the Contract Price.	
<b>1</b>	<b>Incidental Services</b>	15.1	The Supplier may be required to provide any or all of the following services, including additional services, if any, <b>specified in SCC:</b>	
<b>5.</b>			a)	Performance or supervision of on-site assembly and/or start-up of the supplied Goods;
			b)	Furnishing of tools required for assembly and/or maintenance of the supplied Goods;
			c)	Furnishing of a detailed operations and maintenance manual for each appropriate unit of the supplied Goods;
			d)	Performance or supervision or maintenance and/or repair of the supplied Goods, for a period of time agreed by the parties, provided that this service shall not relieve the Supplier of any warranty obligations under this Contract; and.
			e)	Training of the Purchaser's personnel, at the Supplier's plant and/or on-site, in assembly, start-up, operation, maintenance, and/or repair of the supplied Goods.

		15.2	Prices charged by the Supplier for incidental services, if not included in the Contract Price for the Goods, shall be agreed upon in advance by the parties and shall not exceed the prevailing rates charged to other parties by the Supplier for similar services
<b>1</b>	<b>Spare</b>	16.1	As <b>specified in SCC</b> , the Supplier may be required to provide any or all of the following materials, notifications, and information pertaining to spare parts manufactured or distributed by the Supplier:
<b>6.</b>	<b>Parts</b>		a) Such spare parts as the Purchaser may elect to purchase from the Supplier, provided that this election shall not relieve the Supplier of any warranty obligations under the Contract; and
			b) In the event of termination of production of the spare parts: <ul style="list-style-type: none"> <li>i) advance notification to the Purchaser of the pending termination, in sufficient time to permit the Purchaser to procure needed requirements; and</li> <li>ii) Following such termination, furnishing at no cost to the Purchaser, the blueprints, drawings, and specifications of the spare parts, if requested.</li> </ul>

1 7.	<b>Warranty</b>	17.1	The Supplier warrants that the Goods supplied under the Contract are new, unused, of the most recent or current models and those they incorporate all recent improvements in design and materials unless provided otherwise in the Contract. The Supplier further warrants that all Goods supplied under this Contract shall have no defect, arising from design, materials, or workmanship (except when the design and/or material is required by the Purchaser, specifications) or from any act or omission of the Supplier that may develop under normal use of the supplied Goods in the conditions prevailing in Zanzibar.
		17.2	This warranty shall remain valid for a period specified in the <b>SCC</b> after the Goods, or any portion thereof as the case may be, have been delivered to and accepted at the final destination indicated in the Contract, or for a period specified in the <b>SCC</b> after the date of shipment from the port or place of loading in the source country, whichever period concludes earlier, unless <b>specified otherwise in SCC.</b>
		17.3	The Purchaser shall promptly notify the Supplier in writing of any claims arising under this warranty.



		17.4	Upon receipt of such notice, the Supplier shall, within the period <b>specified in SCC</b> and with all reasonable speed, repair or replace the defective Goods or parts thereof, without costs to the Purchaser other than, where applicable, the cost of inland delivery of the repaired or replaced Goods or parts from EXW or the port or place of entry to entry to the final destination.
		17.5	If the Supplier, having been notified, fails to remedy the defect(s) within the period <b>specified in SCC</b> , the Purchaser may proceed to take such remedial action as may be necessary, at the Supplier's risk and expense and without prejudice to any other rights which the Purchaser may have against the Supplier under the Contract.
<b>1</b>	<b>Paymen</b>	18.1	The method and conditions of payment to be made to the Supplier under this Contract shall be <b>specified in SCC</b> .
<b>8.</b>	<b>t</b>	18.2	The Supplier's request(s) for payment shall be made to the Purchaser in writing, accompanied by an invoice describing, as appropriate, the Goods delivered and Services performed, and by documents submitted pursuant to GCC Clause 12, and upon fulfillment of other obligations stipulated in the Contract.

		18.3	The Purchaser shall make payments promptly, within sixty (60) days after submission of an invoice or claim by the Supplier. If the Purchaser makes a late payment, the Supplier shall be paid interest on the late payment. Interest shall be calculated from the date by which the payment should have been made up to the date when the late payment is made at the rate as <b>specified in the SCC</b> .
		18.4	The currency or currencies in which payment is made to the Supplier under this Contract shall be <b>specified in SCC</b> subject to the following general principle: payment will be made in the currency or currencies in which the payment has been requested in the Supplier's Tender.
		18.5	All payments shall be made in the currency or currencies specified in the <b>SCC</b> pursuant to GCC Clause 18.4
<b>1</b>	<b>Prices</b>	19.1	The contract price shall be as specified in the Contract Agreement Subject to any additions and adjustments thereto or deductions there from, as may be made pursuant to the Contract.
<b>9.</b>		19.2	Prices charged by the Supplier for Goods delivered and Services performed under the Contract shall not vary from the prices quoted by the Supplier in its Tender, with the exception of any price adjustments <b>authorized in SCC</b> or in the Purchaser's request for Tender validity extension, as the case may be.

20.	<b>Change Orders</b>	20.1	The Purchaser may at any time, by a written order given to the Supplier pursuant to GCC Clause 21, make changes within the general scope of the Contract in any one or more of the following:
			a) Drawings, designs, or specifications, where Goods to be furnished under the Contract are to be specifically manufactured for the Purchaser;
			b) The method of shipment or packing;
			c) The place of delivery; and/or
			d) The Services to be provided by the Supplier.
		20.2	If any such change causes an increase or decrease in the cost of, or the time required for, the Supplier's performance of any provisions under the Contract an equitable adjustment shall be made in the Contract Price or delivery schedule, or both, and the Contract shall accordingly be amended. Any claims by the Supplier for adjustment under this clause must be asserted within thirty (30) days from the date of the Supplier's receipt of the Purchaser's change order.
		20.3	Prices to be charged by the supplier for any related services that might be needed but which were not included in the Contract shall be agreed upon in advance by the Parties and shall not exceed the prevailing rates charged to other parties by the Supplier for similar services.
21.	<b>Contract Amendments</b>	21.1	Subject to GCC Clause 20, no variation in or modification of the terms of the Contract shall be made except by written amendment signed by the parties.

<b>22</b>	<b>Assignment</b>	22.1	Neither the Purchaser nor the Supplier shall assign, in whole or in part, obligations under this Contract, except with the prior written consent of the other party.
<b>23</b>	<b>Subcontracts</b>	23.1	The Supplier shall notify the Purchaser in writing of all subcontracts awarded under this contract if not already specified in the Tender. Such notification, in the original Tender or later, shall not relieve the Supplier from any liability or obligation under the contract.
		23.2	Subcontracts must comply with the provision of GCC Clause 5.

<b>24</b>	<b>Delays in the Supplier's Performance</b>	24.1	Delivery of the Goods and performance of Services shall be made by the Supplier in accordance with the time schedule prescribed by the Purchaser in the Schedule of Requirements.
		24.2	If at any time during performance of the Contract, the Supplier or its subcontractor(s) should encounter conditions impeding timely delivery of the Goods and performance of Services, the Supplier shall promptly notify the Purchaser in writing of the fact of the delay, its likely duration and its cause(s). As soon as practicable after receipt of the Supplier's notice, the Purchaser shall evaluate the situation and may at its discretion extend the Supplier's time for performance, with or without liquidated damages, in which case the extension shall be ratified by the parties by amendment of Contract.

		24 .3	Except as provided under GCC Clause 27, a delay by the Supplier in the performance of its delivery obligations shall render the Supplier liable to the imposition of liquidated damages pursuant to GCC Clause 25, unless an extension of time is agreed upon pursuant to GCC Clause 24.2 without the application of liquidated damages.
25	<b>Liquidated Damages</b>	25 .1	Subject to GCC Clause 27, if the Supplier fails to deliver any or all of the Goods or to perform the Services within the period(s) specified in the Contract, the Purchaser shall, without prejudice to its other remedies under the Contract, deduct from the Contract Price, as liquidated damages, a sum equivalent to the percentage <b>specified in SCC</b> of the delivered price of the delayed Goods or unperformed Services for each week or part thereof of delay until actual delivery or performance, up to a maximum deduction of the percentage <b>specified in SCC</b> . Once the maximum is reached, the Purchaser may consider termination of the Contract pursuant to GCC Clause 26.
26	<b>Termination for Default</b>	26 .1	The Purchaser or the Supplier, without prejudice to any other remedy for breach of Contract, by written notice of default sent to the concerned party may terminate the Contract if the other party causes a fundamental breach of the Contract.
		26 .2	Fundamental breaches of Contract shall include, but shall not be limited to the following:
			a) the Supplier fails to deliver any or all of the Goods within the period(s) specified

				in the Contract, or within any extension thereof granted by the Purchaser pursuant to GCC Clause 24; or
			b)	the Supplier fails to perform any other obligation(s) under the Contract;
			c)	The supplier has abandoned or repudiated the contract.
			d)	The Purchaser or the Supplier is made bankrupt or goes into liquidation other than for a reconstruction or amalgamation;
			e)	a payment is not paid by the Purchaser to the Supplier within 84 days of the due date for payment;
			f)	the Purchaser gives Notice that goods delivered with a defect is a fundamental breach of Contract and the Supplier fails to correct it within a reasonable period of time determined by the Purchaser; and
			g)	The supplier, in the judgment of the Purchaser, has engaged in corrupt or fraudulent practices in competing for or in exacting the Contract.
				For the purpose of this clause:
				“Corrupt practice” means the offering, giving, receiving, or soliciting of anything of value to influence the action of a public official in the procurement process or in contract execution and includes, inter alia, bribery and extortion or coercion which involves threats of injury to person, property or reputation, and

			“fraudulent practice” means a misrepresentation of facts in order to influence a procurement process or the execution of a contract to the detriment of the Purchaser, and includes collusive practices among Tenderers (prior to or after Tender submission)
		26.4	In the event the Purchaser terminates the Contract in whole or in part, pursuant to GCC Clause 26.1, the Purchaser may procure, upon such terms and in such manner, as it deems appropriate, Goods or Services similar to those undelivered, and the Supplier shall be liable to the Purchaser for any excess costs for such similar Goods or Services. However, the Supplier shall continue performance of the Contract to the extent not terminated.
27	<b>Force Majeure</b>	27.1	Notwithstanding the provisions of GCC Clauses 24, 25, and 26, the Supplier shall not be liable for forfeiture of its performance security, liquidated damages, or termination for default if and to the extent that its delay in performance or other failure to perform its obligations under the Contract is the result of an event of Force Majeure. Such events may include, but are not restricted to, acts of the Purchaser in its sovereign capacity, wars or revolutions, fires, floods, epidemics, quarantine, restrictions, acts of terrorists and freight embargoes.

		27 .2	If a Force Majeure situation arises, the Supplier shall promptly notify the Purchaser in writing of such condition and the cause thereof. Unless otherwise directed by the Purchaser in writing, the Supplier shall continue to perform its obligations under the Contract as far as is reasonably practical, and shall seek all reasonable alternative means for performance not prevented by the Force Majeure event.
28	<b>Termination for Insolvency</b>	28 .1	The Purchaser may at any time terminate the Contract by giving written notice to the Supplier if the Supplier becomes bankrupt or otherwise insolvent. In this event, termination will be without compensation to the Supplier, provided that such termination will not prejudice or affect any right of action or remedy that has accrued or will accrue thereafter to the Purchaser
29	<b>Termination for Convenience</b>	29 .1	The Purchaser, by written notice sent to the Supplier, may terminate the contract, in whole or in part, at any time for its convenience. The notice of termination shall specify that termination is for the Purchaser's convenience, the Contract is terminated, and the date upon which such termination becomes effective.
		29 .2	The Purchaser shall accept the Goods that are complete and ready for shipment within thirty (30) days after the Supplier's receipt of notice of termination at the Contract terms and price. For the remaining Goods, the Purchaser may elect:
			a) To have any portion completed and delivered at the Contract terms and prices; and / or



			b)	To cancel the remainder and pay to the Supplier an agreed amount for partially completed Goods and Services and for materials and parts previously procured by the Supplier.
<b>30</b>	<b>Disputes</b>	30	.1	If any dispute or difference of any kind whatsoever shall arise between the Purchaser and the Supplier in connection with or arising out of the Contract, the parties shall make every effort to resolve amicably such dispute or difference by mutual consultation.
		30	.2	If after thirty days, the parties have failed to resolve their dispute or difference by such mutual consultation, and then either the Purchaser or the Supplier may give notice for arbitration
		30	.3	If the either party believes that a decision taken by the other was wrongly taken, the decision shall be referred to the Arbitration within 14 days of the notification of the decision.
<b>31</b>	<b>Procedure for Disputes</b>	31	.1	The Arbitration shall stated in the <b>SCC</b> give a decision in writing within 28 days of receipt of a notification of a dispute.

		31 .2	The Arbitrator shall be paid by the hour at the rate specified in the <b>SCC</b> , together with reimbursable expenses of the types specified in the <b>SCC</b> , and the cost shall be divided equally between the Purchaser and the Supplier, whatever decision is reached by the Arbitrator. Either party may refer a decision to an Arbitrator within 28 days of the written decision. If neither party refers the dispute to arbitration within the above 28 days, the Arbitrator's decision will be final and binding.
		31 .3	The arbitration shall be conducted in accordance with the arbitration procedure published by the institution named and in the place shown in the <b>SCC</b> .
<b>32</b>	<b>Replacement of Arbitrator</b>	32 .1	Should the Arbitrator resign or die, or should the Purchaser and the Supplier agree that the Arbitrator is not functioning in accordance with the provisions of the Contract a new Arbitrator will be jointly appointed by the Purchaser and the Supplier. In case of disagreement between the Purchaser and the Supplier, within 30 days, the Arbitrator shall be designated by the Appointing Authority designated in the <b>SCC</b> at the request of either party, within 14 days of receipt of such request.
<b>33</b>	<b>Limitation of Liability</b>	33 .1	Except in cases of criminal negligence or willful conduct, and in the case of infringement pursuant to GCC Clause 8,
			a) The supplier shall not be liable to the Purchaser, whether in contract, tort, or otherwise, for any indirect or consequential loss or damage, loss of use, loss of production, or loss of profits

			or interest costs, provided that this exclusion shall not apply to any obligation of the Supplier to pay liquidated damages to the Purchaser; and
		b)	The aggregate liability of the Supplier to the Purchaser, whether under the Contract, in tort or otherwise, shall not exceed the total Contract Price, provided that this limitation shall not apply to the cost of repairing or replacing defective equipment or to any obligation of the Supplier to indemnify the Purchaser with respect to patent infringement..
<b>34</b>	<b>Notices</b>	34 .1	Any notice given by one party to the other pursuant to this Contract shall be sent to the other party in writing or by cable, telex, or facsimile and confirmed in writing to the other party's address <b>specified in SCC</b> . The term "in writing" means communicated in written form with proof of receipt.
		34 .2	A notice shall be effective when delivered or on the notice's effective date, whichever is later.
<b>35</b>	<b>Taxes and Duties</b>	35 .1	A foreign Supplier shall be entirely responsible for all taxes, stamp duties, license fees, and other such levies imposed outside the Zanzibar.
		35 .2	If any tax exemptions, reductions, allowances or privileges may be available to the Supplier in Zanzibar, the Purchaser shall use its best efforts to enable the Supplier to benefit from any such tax savings to the maximum allowable extent.

		35 .3	A local Supplier shall be entirely responsible for all taxes, duties, license fees, etc., incurred until delivery of the contracted Goods to the Purchaser.
--	--	----------	---



### Special Conditions of Contract

The following Special Conditions of Contract shall supplement the General Conditions of Contract. Whenever there is a conflict, the provisions herein shall prevail over those in the General Conditions of Contract. The corresponding clause number of the GCC is indicated in parentheses.

SCC Clause Number	GCC Clause Number	Amendments of, and Supplements to, Clauses in the General Conditions of Contract
<b>Definitions (GCC Clause 1)</b>		
1.	1.1(i)	<b>The Purchaser is:</b> Zanzibar Electricity Corporation P. O Box 235 Gulioni, Zanzibar.
2.	1.1(j)	<b>The Supplier is:</b> Fasima General Traders of P. O BOX 3654, Mwembeladu, Zanzibar.
3	2	<b>Contract effectiveness:</b> The contract become effective from the day of being signed.
4		<b>Contract Price:</b> TZS 1,650,995,880.00/, VAT INCLUSIVE, DDP Saateni Main Store Zanzibar
5	2	<b>Quantity:</b> as per the respective order (the goods details in the Price Schedule being the first order
<b>Governing Language (GCC Clause 3)</b>		
6	3.1	<b>The Governing Language shall be:</b> English.
<b>Applicable Law (GCC Clause 4)</b>		
7	4.1	<b>The Applicable Law shall be:</b> Laws of Zanzibar.
<b>Country of Origin (GCC Clause 5)</b>		
8	5.1	Country of Origin is required: China
<b>Performance Security (GCC Clause 9)</b>		

9	9.1	<b>The amount of performance security, as a percentage of the Contract Price, shall be 10%</b> of contract price. The performance security shall be in the form of Unconditional Bank Guarantee or Certified Check.
	9.2	<b>The performance security will be discharged</b> by the Purchaser and returned to the Supplier in not later than (30) days following the date of completion of the Supplier's obligations performance under the contract including any warranty obligations.
<b>Inspections and Tests (GCC Clause 10)</b>		
11	10.1	<p>Inspection and tests prior to shipment of Goods and at final acceptance are as follows:</p> <p>Quality and quantity inspection shall be carried out prior to shipment of Goods by the manufacturer(s) at the supplier's own expense and responsibility in terms of the items specified in the specifications. The supplier shall submit the inspection certificate issued by him that should be attached with the certificate(s) of the manufacturer(s) to the Procuring Entity in order to ensure that the goods are manufactured in compliance with the contract. <b>Factory Acceptance Test (FAT) will also be witnessed by at least two representatives from ZECO whereby all costs of the representatives from ZECO shall be borne by Supplier.</b> In order to facilitate this, the Supplier shall give <b>ZECO</b> a minimum of four weeks' notice that the materials are ready for testing. <b>NOT APPLICABLE</b></p>
<b>Packing (GCC Clause 11)</b>		

12.	11.2	<p>The following SCC shall supplement GCC Clause 11.2</p> <p>The Goods shall be packed properly in accordance with standard export packing specified by the Procuring Entity in the Technical Specification.</p>
<b>Delivery and Documents (GCC Clause 12)</b>		
13	12.1	<p><b>For Goods supplied from abroad:</b></p> <p>Upon shipment, the Supplier shall notify the Procuring Entity and the Insurance Company by cable the full details of the shipment, including Contract number, description of Goods, quantity, the vessel, the bill of lading number and date, port of loading, date of shipment, port of discharge, etc. The Supplier shall mail the following documents to the Procuring Entity, with a copy to the Insurance Company:</p> <p>(i.) One original plus four copies of the Supplier's invoice showing Goods' description, quantity, unit price, and total amount;</p> <p>(ii.) original and four copies of the negotiable, clean, on-board bill of lading marked "freight prepaid" and four copies of nonnegotiable bill of lading;</p> <p>(iii.) One original plus four copies of the packing list identifying contents of each package;</p> <p>(iv.) Insurance certificates ;</p>

		<p>(v.) Manufacturer's or Supplier's warranty certificate;</p> <p>(vi.) inspection certificate, issued by the nominated inspection agency, and the Supplier's factory inspection report; and</p> <p>(vii.) Certificate of country of origin issued by the chamber of commerce and industry or equivalent authority in the country of origin in duplicate.</p> <p>The above documents shall be received by the Procuring and Disposing Entity at least one week before arrival of the Goods at the port or place of arrival and, if not received, the Supplier will be responsible for any consequent expenses.</p>
13.	12.3	<p><b>For Goods from/ within Zanzibar or Tanzania mainland.</b></p> <p>Upon delivery of the Goods to the transporter, the Supplier shall notify the Procuring and Disposing Entity and mail the following documents to the Procuring and Disposing Entity:</p> <p>(i.) one original plus four copies of the Supplier's invoice showing Goods' description, quantity, unit price, and total amount;</p> <p>(ii.) delivery note, ship receipt, or truck receipt;</p> <p>(iii.) Manufacturer's or Supplier's warranty certificate;</p>



		<p>(iv.) inspection certificate issued by the nominated inspection agency, and the Supplier's factory inspection report; and</p> <p>(v.) Certificate of country of origin issued by the Zanzibar Chamber of Commerce, Industry and Agriculture or equivalent authority in the country of origin in duplicate.</p> <p>The Procuring and Disposing Entity shall receive the above documents before arrival of the Goods and, if not received, the Supplier will be responsible for any consequent expenses. <b>NOT APPLICABLE</b></p>
<b>Insurance (GCC Clause 13)</b>		
14.	13.1	The Insurance shall be in an amount equal to 110 percent of the DDP value of the Goods from "warehouse" to "Point of destination (DDP Saateni main Store" on "All Risks" basis, including War Risks and Strikes.
<b>Incidental Services (GCC Clause 15)</b>		
15.	15.1	Incidental services to be provided are: <b>Not Applicable</b>
<b>Spare Parts (GCC Clause 16)</b>		
16.	16.1	Additional spare parts requirements are: <b>NOT APPLICABLE.</b>
<b>Warranty (GCC Clause 17)</b>		
17.	17.2	GCC 17.2—In partial modification of the provisions, the warranty period shall be <b>12 months</b> from date of acceptance of the Goods.

		<p>The Supplier shall, in addition, comply with the performance and/or consumption guarantees specified under the Contract. If, for reasons attributable to the Supplier, these guarantees are not attained in whole or in part, the Purchaser shall, at its discretion, either:</p> <p>(a) Order Supplier to make such changes, modifications, and/or additions to the Goods or any part thereof as may be necessary in order to attain the contractual guarantees specified in the Contract at Supplier own cost and expense and to carry out further performance tests in accordance with SCC 14,</p> <p><b>or</b></p> <p>(b) Order Supplier to pay liquidated damages to the Procuring and Disposing Entity with respect to the failure to meet the contractual guarantees. The rate of these liquidated damages shall be 0.20 per cent per day of undelivered materials/goods value up to the sum equivalent to the amount of ten percent of the contract value.</p>
18.	17.4 & 17.5	The period for correction of defects in the warranty period is: <b>One month.</b>
<b>Payment (GCC Clause 18)</b>		
19.	18.1	<p>The method and conditions of payment to be made to the Supplier under this Contract shall be as follows:</p> <p>i) After fulfilment of all required obligations 100% of the contract price shall be paid upon submission of claim supported by Bill of Lading, Commercial Invoice and other relevant documents.</p>

18.2 ii) After fulfilment of delivered of goods at Zanzibar Saateni main store, and to be accepted by the Client.

The payment shall be paid to Supplier through Supplier's Bank stated below:

Name of Bank: CRDB Bank,

Address of Bank: Zanzibar Branch,

Account Name: Fasima General Traders Co. Ltd

Account Number No: 09602832000,

Currency: TZS.

**Payment for Goods supplied from abroad:**

Payment of foreign currency shall be made in the following manner:

(i) **Advance Payment: NOT APPLICABLE.**

Percent of the Contract Price shall be paid within thirty (30) days of signing of the Contract, and upon submission of claim and a bank guarantee for equivalent amount valid until the Goods are delivered and in the form provided in the Tendering documents or another form acceptable to the Procuring and Disposing Entity.

(ii) **On Shipment: NOT APPLICABLE.**

percent of the Contract Price of the Goods shipped shall be paid through irrevocable confirmed letter of credit opened in favor of the Supplier in a bank in its country.

		(iii) <b>On Acceptance: 100</b> Percent of the Contract Price of Goods received shall be paid upon submission of claim supported by bill of lading and other documents required by purchaser through the selected reputable bank by the Procuring and Disposing Entity.
		<b>Payment for Goods and Services supplied,</b> as follows.  (i) <b>Advance Payment: NOT APPLICABLE.</b> Percent of the Contract Price shall be paid within thirty (30) days of signing of the Contract against a simple receipt and a bank guarantee for the equivalent amount and in the form provided in the Tendering documents or another form acceptable to the Procuring and Disposing Entity.  (ii) <b>On Delivery: NOT APPLICABLE.</b> Percent of the Contract Price shall be paid on receipt of the Goods and upon submission of the documents specified in GCC Clause 10.  (iii) <b>On Acceptance: 100</b> Percent of the Contract Price of Goods received shall be paid within thirty (30) days of receipt of the Goods upon submission of claim supported by the acceptance certificate issued by the Procuring and Disposing Entity. <b>NOT APPLICABLE</b>
19.	18.3	Rate to be used for paying the Supplier's interest on the late payment made by Purchaser shall be: <b>NOT APPLICABLE.</b>
<b>Contract Amendments (GCC Clause 21)</b>		
20	21.1	a. This agreement may not be amended, or otherwise extended, except by written agreement between the parties and no other

		<p>purported amendment or extension thereof shall be effective.</p> <p>b. The Contract shall be valid until after fulfillment of all delivery and this contract shall commence from the date of signing the contract</p>
<b>Prices (GCC Clause 19)</b>		
21.	19.1	Prices shall be adjusted in accordance with provisions in the Attachment to SCC. <b>NOT APPLICABLE.</b>
<b>Delays in the Supplier's Performance(GCC Clause 24)</b>		
22	24	The goods shall be delivered at Saateni Zeco Main Store in Zanzibar within the period specified in the Tender Document from the effective date of signing the contract.
<b>Liquidated Damages (GCC Clause 25)</b>		
23.	25.1	Applicable rate: 0.2 per cent per day of undelivered materials/good's value. Maximum deduction: is equal to the performance security.
<b>Procedure for Disputes (GCC Clause 31)</b>		
24.	31.1	The Dispute shall be referred to Zanzibar Commercial Court.
<b>Notices (GCC Clause 34)</b>		
25.	34.1	Procuring and Disposing Entity's address for notice purposes: The General Manager Zanzibar Electricity Corporation, P.O. Box 235, Gulioni, <b><u>ZANZIBAR</u></b>

		Managing Director, Fasima General Traders, P. O BOX 3654, Mwembeladu, <b><u>ZANZIBAR</u></b>
--	--	--



## Power of Attorney

TO ALL IT MAY CONCERN

THAT BY THIS POWER OF ATTORNEY given on the 21st December 2021, WE the undersigned **Fasima General Traders Ltd** of P.O.BOX 3654, Muembeladu, Zanzibar, by virtue of authority conferred to us by the Board Resolution No. FASIMA/ZECO/2021/09 of day of 21st December 2021, do hereby ordain nominate and appoint **RAJAB MOHAMMED MGENI** of P.O.Box 3654, Zanzibar to be our true lawful Attorney and Agent, with full power and authority, for us and in our names, and for our accounts and benefits, to do any, or all of the following acts, in the execution of tender No. SMZ/F0120/G/RNCB/2021-2022/04

that is to say; To act for the company and do any other thing or things incidental for SMZ/F0120/G/RNCB/2021-2022/04 of SUPPLY OF HIGH TENSION AND LOW-TENSION MATERIALS UNDER THE COVID-19 PROJECT for the Zanzibar Electricity Corporation.

AND provided always that this Power of Attorney shall not revoke or in any manner affect any future power of attorney given to any other person or persons for such other power or powers shall remain and be of the same force and affect as if this deed has not been executed.

AND we hereby undertake to ratify everything, which our Attorney or any substitute or substitutes or agent or agents appointed by him under this power on his behalf herein before contained shall do or purport to do in virtue of this Power of Attorney.

SEALED with the common seal of the said FASIMA GENERAL TRADERS COMPANY LTD and delivered in the presence of us this 21<sup>st</sup> day of December 2021.

IN WITNESS whereof we have signed this deed on this 21st day of December 2021 at Mjini Maghrib for and on behalf of FASIMA GENERAL TRADERS COMPANY LTD.

SEALED and DELIVERED by the  
Common Seal of RAJAB MOHAMMED MGENI  
This 21<sup>st</sup> December 2021

  
.....  
DONOR

BEFORE ME:

  
.....  
COMMISSIONER FOR THE HIGH COURT  
JUDICIAL PUBLIC AND  
COMMISSIONER





ELECTRICITY CORPORATION

HIGH TENSION AND LOW-TENSION MATERIALS UNDER THE  
PROJECT

D. SMZ/F0120/G/RNCB/2021-2022/04

THE REVOLUTIONARY GOVERNMENT OF ZANZIBAR  
MEMORANDUM FOR ANTI-BRIBERY POLICY

FASIMA GENERAL TRADERS COMPANY LTD places importance on bidding taking place on a basis that is free, fair, and competitive and not open to manipulation. We are pleased to confirm that it will not offer or facilitate, directly or indirectly, any payment or reward to any public officer, their relations or business associates, in connection with its bid, or in the subsequent performance of the contract if it is successful.

We have an Anti-Bribery Policy/ Code of Conduct and a Compliance Program in place and we will take all reasonable steps necessary to assure that the No-bribery commitment statement will be complied with by its managers and employees as well as by subcontractors working with this company on the public sector projects or contracts. Consultants, consortium partners, sub-contractors and suppliers. Copies of our Anti-Bribery Policy/Code of Conduct and Compliance Program are attached.



FASIMA GENERAL TRADERS  
Box: 3654  
TEL: 2552422 30504/5  
FAX: 129-190-957  
ZRB: 070-001-957  
Z: 025387285  
ZANZIBAR

in the capacity of

Managing Director

RAJAB MOHAMMED MGENI

BOX3654, Muembeladu, Zanzibar

15th day of December, 2021

Authorized to sign the bid for and on behalf of FASIMA GENERAL TRADERS

LA  
DERS

2-15 PROJEC





## Schedule of Requirement and Price

SUPPLY OF HIGH TENSION AND LOW-TENSION MATERIALS UNDER THE COVID-19 PROJECT

SMZ/F0120/G/RNCB/2021-2022/04

LOT 2 B

	PARTICULAR	QTY	DDP UNIT PRICE (VAT EXCLUSIVE)	DDP UNIT PRICE TO THE POINT OF DESTINATION (VAT INCLUSIVE)	TOTAL DDP PRICE VAT EXCLUSIVE	DDP TOTAL AMOUNT VAT EXCLUSIVE
1	Roof Pole Materials	30,000	43,913	50,500	1,317,391,304	1,515,000,000
2	Fisher	419,998	52	60	21,912,939	25,199,880
3	Screws	420,000	104	120	43,826,087	50,400,000
4	Meter Seal	30,198	1,739	2000	52,518,261	60,396,000
<b>Total Amount in TZS</b>					<b>1,435,648,591</b>	<b>1,650,995,880</b>

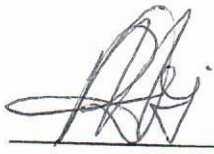

RAJAB MOHAMMED MGENI



In the capacity of :

Managing Director

Duly authorized to sign bid for and on behalf of : FASIMA GENERAL TRADERS





# FASIMA GENERAL TRADERS COMPANY LIMITED

Dealers in Stay rod Material, insulation piercing connector, Cross arm, Building Material and  
Other General Supply

Head Office:  
P.O BOX 3654  
Muembe Ladu  
Zanzibar

Office: +255777413898  
+255777426474  
Email: rajabmus@yahoo.com

## FORM OF TENDER

21<sup>st</sup> December 2021

Zanzibar Electricity Corporation,  
P.O.Box 235,  
Zanzibar.

### *SUPPLY OF HIGH TENSION AND LOW-TENSION MATERIALS UNDER THE COVID-19 PROJECT*

*TENDER NO. SMZ/F0120/G/RNCB/2021-2022/04*

- (a) We have examined and have no reservations to the Bidding Documents, including Addenda issued in accordance with Instructions to Bidders ITB 9
- (b) We meet the eligibility requirements and have no conflict of interest in accordance with ITB 4;
- (c) We have not been suspended nor declared ineligible by the Purchaser based on execution of a Bid Securing Declaration in the Purchaser's country in accordance with ITB 18

We offer to supply in conformity with the Bidding Documents and in accordance with the Delivery Schedules specified in the Schedule of Requirements the following Goods:  
**Supply of High Tension and Low-Tension Materials Under the Covid-19 Project;**

- (d) The total price of our Bid, excluding any discounts offered in item (f) below is:

The Sum of is **One Billion Six Hundred Fifty Million Nine Hundred Ninety-Five Thousand Eight Hundred Eighty Tanzania Shillings (TZS. 1,650,995,880) VAT Inclusive for LOT 2 B;**

- (a) The discounts offered and the methodology for their application are:
- (i) The discounts offered are: [NA]
- (ii) The exact method of calculations to determine the net price after application of discounts is shown below: [NA];
- (b) Our bid shall be valid for a period of 120 days from the date fixed for the bid submission deadline in accordance with the Bidding Documents, and it shall remain binding upon us and may be accepted at any time before the expiration of that period;
- (c) [Applicable] If our bid is accepted, we commit to obtain a Performance Security in accordance with the Bidding Documents;
- (d) We accept that **Zanzibar Attorney General Chamber** be appointed as the Adjudicator;
- or
- (e) We do not accept that [name proposed by Purchaser] be appointed as Adjudicator, we are hereby proposing [name proposed by the Supplier] be appointed as Adjudicator. The Biography of [insert the name of the Adjudicator proposed by the Supplier] is attached with this form. N/A
- (f) We are not participating, as a Bidder in more than one bid in this bidding process other than alternative bids submitted in accordance with ITB 19;
- (g) Our firm, its affiliates or subsidiaries - including any subcontractors or suppliers for any part of the contract - has not been declared ineligible by the Revolutionary Government of Zanzibar under Zanzibar's laws or official regulations or by an act of compliance with a decision of the United Nations Security Council;
- (h) We are not a government owned entity/ We are a government owned entity but meet the requirements of ITB 3.5;
- (i) We have paid, or will pay the following commissions, gratuities, or fees with respect to the bidding process or execution of the Contract: N/A

Name of Recipient	Address	Reason	Amount

(If none has been paid or is to be paid, indicate "none.")

- (j) We understand that this bid, together with your written acceptance thereof included in your notification of award, shall constitute a binding contract between us, until a formal contract is prepared and executed; and
- (k) We understand that you are not bound to accept the lowest evaluated bid or any other bid that you may receive.
- (l) We undertake that, in competing for (and, if the award is made to us, in executing) the above contract, we will strictly observe the laws against fraud and corruption in force in Zanzibar;



In the capacity of :

RAJAB MOHAMMED MGENI

Managing Director

Duly authorized to sign bid for and on behalf of : FASIMA GENERAL TRADERS





# FASIMA GENERAL TRADERS COMPANY LIMITED

Dealers in Stay rod Material, insulation piercing connector, Cross arm, Building Material and Other General Supply

Head Office:  
P.O BOX 3654  
Muembe Ladu  
Zanzibar

Office: +255777413898  
+255777426474  
Email: rajabmus@yahoo.com

## Schedule of Requirement

SUPPLY OF HIGH TENSION AND LOW-TENSION MATERIALS UNDER THE COVID-19 PROJECT

SMZ/F0120/G/RNCB/2021-2022/04

### LOT 2 B

	PARTICULAR	QTY
1	Roof Pole Materials	30,000
2	Fisher	419,998
3	Screws	420,000
4	Meter Seal	30,198

  
GENERAL TRADERS  
Box: 3654  
Tel: 2552422 36504/5  
Tel: 120 100 857  
ZPB: 070-001-957  
ZANZIBAR  
RAJAB MOHAMMED MGENI

In the capacity of :  
Managing Director

Duly authorized to sign bid for and on behalf of : FASIMA GENERAL TRADERS

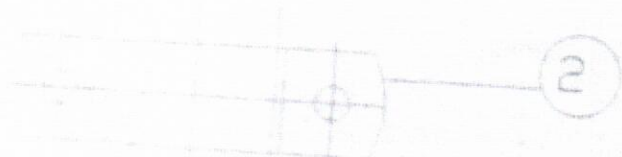
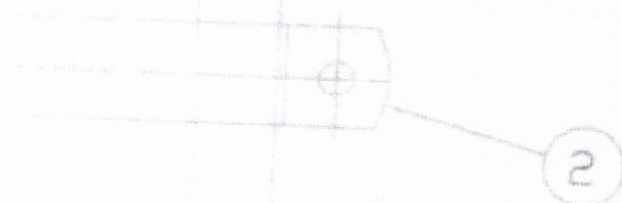
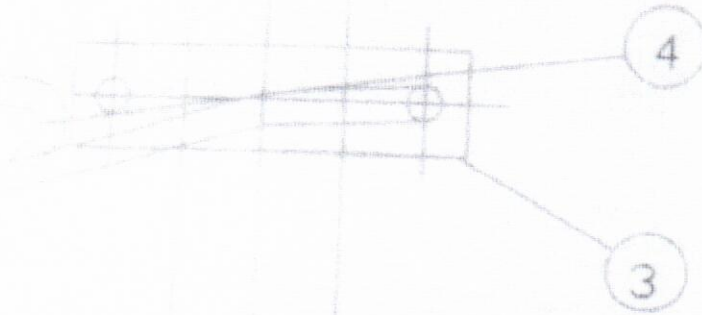
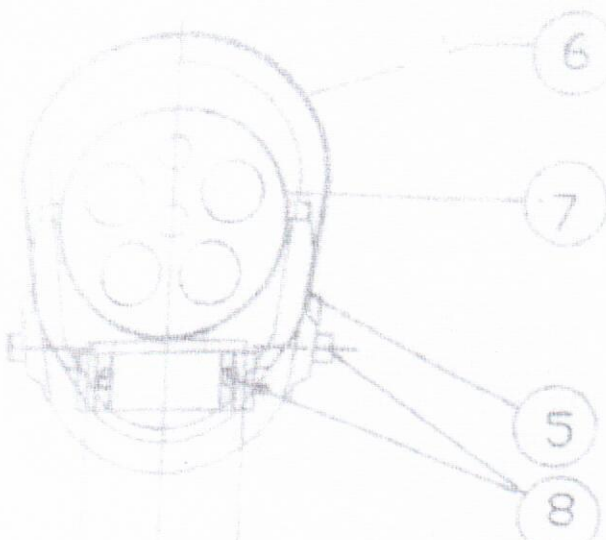

8	SCREW 1/4 B.S.W.	
7	PLASTIC PIECE	SM-27E
6	HOUSING	SM-27D
5	BRACKET	SM-27C
4	BOLT	SM-27B
3	CLAMP	SM-27A
2	CLAMP	SM-27A
1	GI PIPE	SM-27A
Q'NO	DESCRIPTION	Q'NO

DATE	DESIGN		
BY	CHKD		
NO	REVISED		
SCALE	NOTES		

APPROVED  
 REVISIONS  
 MATERIALS  
 FINISHING  
 INSPECTION  
 STORAGE

*[Handwritten signature]*

*[Handwritten initials]*